

June 16, 1925.

1,541,845

M. I. PUPIN

ELECTRICAL WAVE TRANSMISSION

Original Filed Dec. 11, 1915 2 Sheets-Sheet 1

Fig. 1.

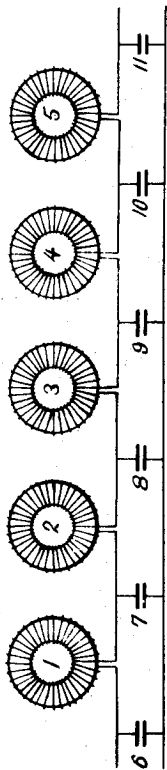

Fig. 2.

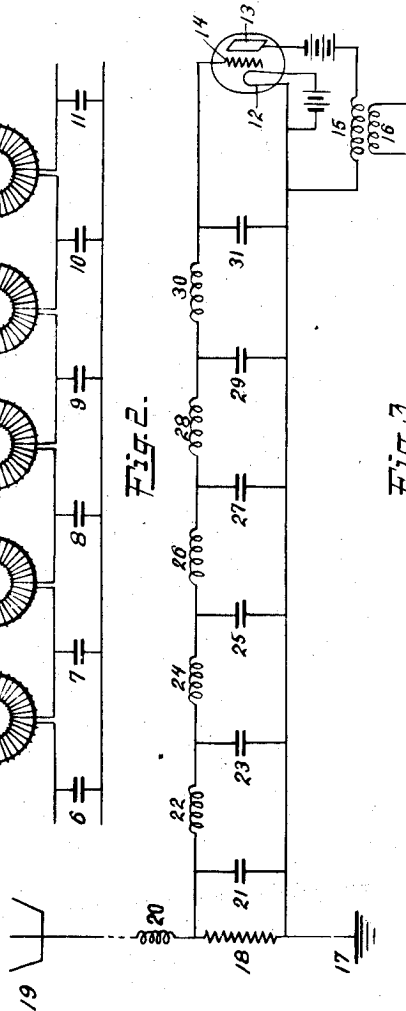

Fig. 3.

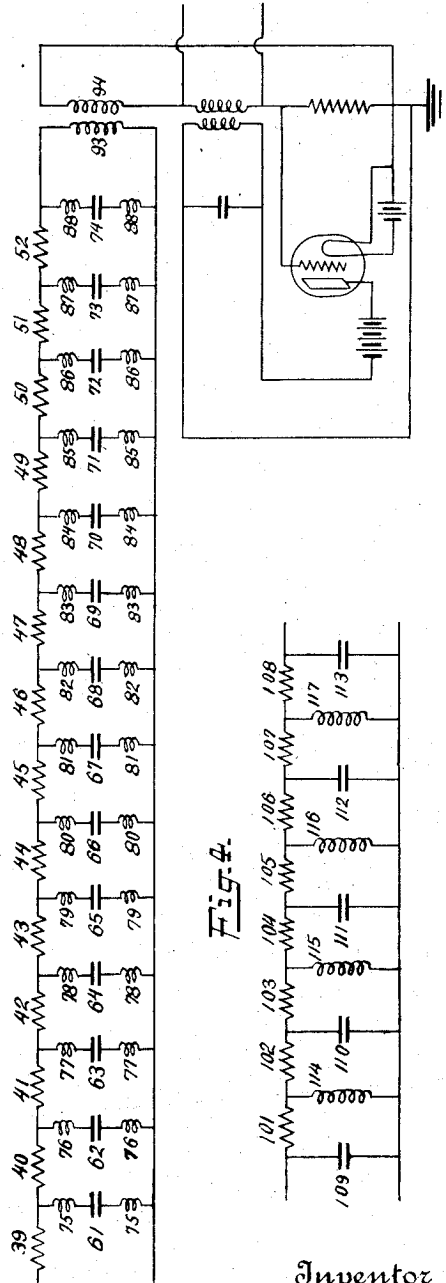
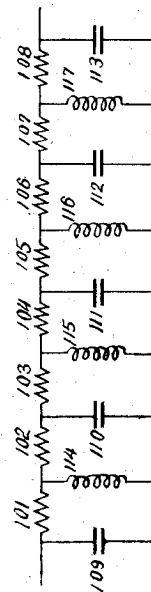

Fig. 4.



Inventor

Michael I. Pupin

By his Attorneys

Renis Davis-Maron

June 16, 1925.

1,541,845

M. I. PUPIN

ELECTRICAL WAVE TRANSMISSION

Original Filed Dec. 11, 1915 2 Sheets-Sheet 2

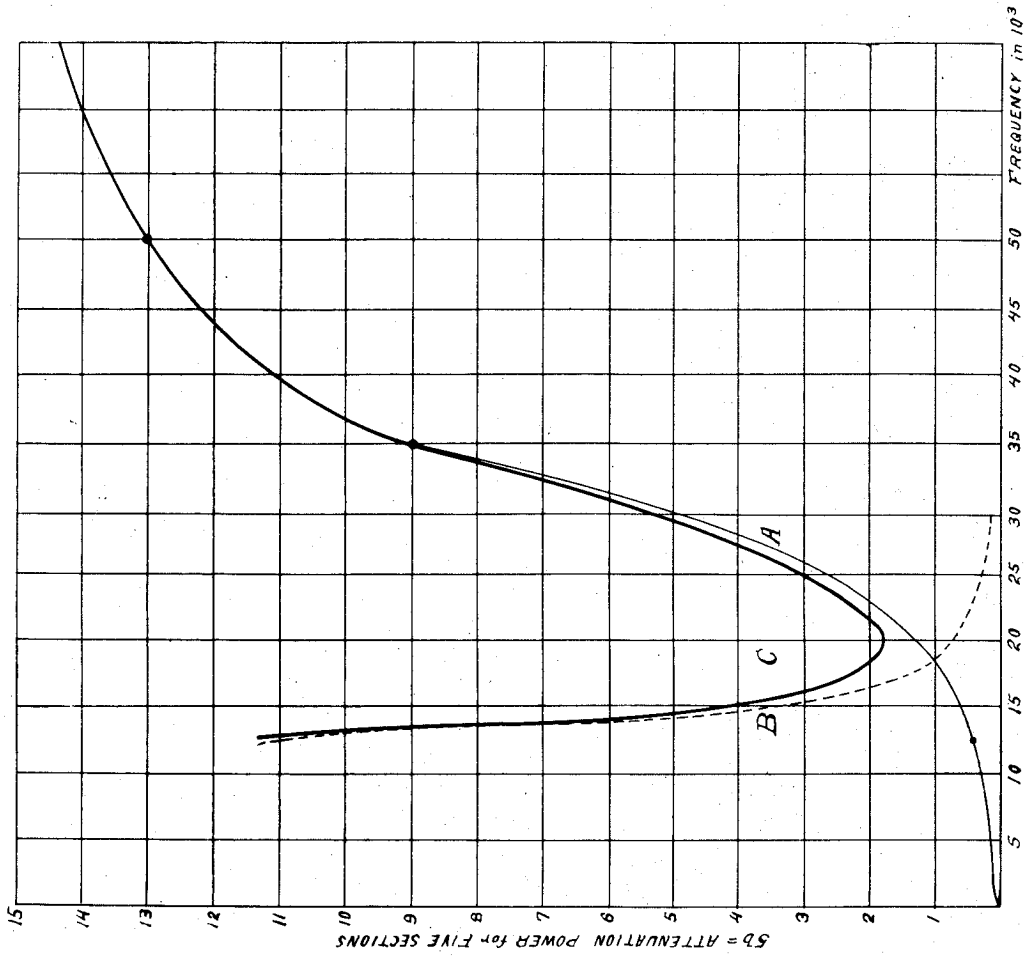

Fig. 5.

Inventor

Michael I. Pupin

By his Attorneys

Rennie David Maron

UNITED STATES PATENT OFFICE.

MICHAEL I. PUPIN, OF NORFOLK, CONNECTICUT, ASSIGNOR TO WESTINGHOUSE ELECTRIC AND MANUFACTURING COMPANY, OF EAST PITTSBURGH, PENNSYLVANIA, A CORPORATION OF PENNSYLVANIA.

ELECTRICAL WAVE TRANSMISSION.

Application filed December 11, 1915, Serial No. 430,995. Renewed December 15, 1920.

To all whom it may concern:

Be it known that I, MICHAEL I. PUPIN, a citizen of the United States, residing in Norfolk, county of Litchfield, State of Connecticut, have invented certain new and useful Improvements in Electrical Wave Transmissions; and I do hereby declare the following to be a full, clear, and exact description of the invention, such as will enable others skilled in the art to which it appertains, to make and use the same.

This invention relates to an improvement in electrical wave transmission and consists in interposing one or more suitably constructed sectional wave conductors (called here the "pilot" wave conductors) between the wave conductor which receives the electrical wave energy and the local translating devices which are to be actuated by this energy. The object of the invention is to exclude from the circuits containing the translating devices all electrical waves which are not intended for them.

Referring to the diagrams of the drawings which form a part of this specification;

Figure 1 is a diagram of a sectional wave conductor consisting of approximately equal inductance coils shunted by approximately equal condensers;

Fig. 2 is a diagram representing a sectional wave conductor interposed between a wireless receiving antenna and the circuits containing local translating devices.

Fig. 3 is a diagram representing a sectional wave conductor of a different type from that in Fig. 1 and Fig. 2, interposed between the system of conductors represented in Fig. 2 and the local receiving devices.

Fig. 4 is a third type of sectional wave conductor.

Fig. 5 is a diagram representing by curves the relation between the attenuation power and frequency in the sectional wave conductors of Fig. 2 and of Fig. 3, and the same relation when the effects of these two sectional wave conductors are combined.

Referring to Fig. 1, the elements 1, 2, 3, 4, 5, are inductance coils connected in series. They should preferably be approximately equal. Condensers 6, 7, 8, 9, 10, 11, are connected in parallel with the inductance coils; they should also be approximately equal to each other. Assume that there are five coils and six condensers. They form a sectional wave conductor of five sections and having characteristics which will be now discussed.

The theory of the electrical motion in sectional wave conductors was first published by the applicant in 1899 in the Transactions of the American Institute of Electrical Engineers, Vol. XVI, pp 91-142, to which reference is made for the mathematical theory underlying this invention. Reference should also be made to the applicant's publication in Vol. XVII of the same transactions, pages 445-507.

Let L =inductance in henrys of each coil
 C =capacity in farads of each condenser
 R =resistance associated with each coil

Then if b and a denote the attenuation constant and the wave length constant per section, we shall have

$$\begin{aligned} 2 \cosh b \cos a &= 2 - p^2 LC = A \\ 2 \sinh b \sin a &= pCR = B \end{aligned}$$

where

$$\cosh b = \frac{1}{2}(e^b + e^{-b}), \sinh b = \frac{1}{2}(e^b - e^{-b})$$

From these the following formula follows:

$$2 \cosh 2b = \frac{A^2 + B^2}{2} + \sqrt{\frac{(A^2 + B^2)^2}{4} - 2(A^2 - B^2 - 2)}$$

Let $L = 8 \times 10^{-8}$ henrys
 $C = 2 \times 10^{-8}$ farads
 $R = 170$ ohms at 25×10^3 periods = $r_1 + r_2$
 where

$$r_1 = 70r_2 = \frac{100n^2}{4}$$

Let $p_0^2 LC = 1$, when $p_0 = 2\pi \times 12500$, approximately.

$$p_0 CR = .147.$$

The shortest natural period of the sectional wave conductor is that of one of its sec-

tions, which is approximately

$$\frac{\sqrt{2}}{25 \times 10^3} \text{ seconds.}$$

$$A = 2 - \left(\frac{p}{p_0}\right)^2 p_0^2 LC = 2 - n^2$$

$$B = .147n$$

$$n = \frac{f}{f_0}$$

where f is any frequency, and $f_0 = \frac{p_0}{2\pi}$

15 Giving n successively the value $\frac{1}{4}, \frac{1}{3}, \frac{1}{2}, 1, 2,$
 3, . . . the values of b and of $5b$ (the
 attenuation power) for various frequen- 80
 cies was obtained. In Fig. 5 a graphi-
 cal representation is given of the relation 85
 between $5b$ and the frequency. The atten-
 uation factor for the frequency for which $5b$
 has been calculated is e^{-5b} , that is to say,
 a wave of amplitude I at the beginning
 25 of the sectional wave conductor will have
 an amplitude equal to Ie^{-5b} at the end. It is
 easily seen from the curve in Fig. 5 that
 if 25×10^3 p. p. s. is the signalling frequency,
 then all frequencies appreciably higher than
 30 the signalling frequency will be rapidly at-
 tenuated. The frequencies below the signal-
 ling frequency will be transmitted very well.

In other words, this pilot conductor has
 a sufficiently large number of sections per
 35 wave length for frequencies lower than the
 signalling frequency, but for frequencies
 higher than the signalling frequency the
 number of sections per wave length becomes
 small. This structural characteristic in sectional
 40 conductors of this type gives the atten-
 uation power characteristic represented by
 curve A in Fig. 5.

In wireless telegraphy and telephony
 much interference is experienced from the
 45 induction effects produced in the receiving
 antenna by the action of electrical dis-
 charges in the atmosphere. These discharges
 are called strays, atmospherics, or statics.
 It is a well established fact that a large part
 50 of these discharges are very short pulses
 and act like a very high frequency simple
 harmonic electromotive force of very high
 damping. Their frequency is much higher
 than 25×10^3 p. p. s., which is the signalling
 55 frequency usually adopted for long distance
 wireless telegraph work. A wireless receiv-
 ing station in which a sectional wave con-
 ductor just described is employed as a pilot
 wave conductor, that is for connecting the
 60 antenna to the local circuits, containing the
 translating devices, will be screened against
 these high frequency electrical disturbances.
 Such an arrangement is shown in the dia-
 gram of Fig. 2.

65 In this diagram, an antenna 17, 18, 19,

20, grounded at 17, is connected to the pilot
 wave conductor 21, 22, 23, . . . 31. The
 pilot wave conductor is connected to a re-
 peater which is here represented symboli- 70
 cally by the well known vacuum tube having
 a hot cathode 12, a cold anode 13, and a
 third electrode 14, the so-called grid. The
 apparatus to be actuated by the electromo-
 tive force generated by the energizing cir-
 75 cuit 13, 15, 12, is connected to the secondary
 winding 15, 16.

The protection against disturbing elec-
 trical discharges in the atmosphere which
 the sectional wave conductor just described 80
 gives to the circuits containing the translat-
 ing devices can be further increased as fol-
 lows: A high frequency electrical pulse can-
 not be transmitted directly along the sec-
 tional wave conductor represented in Fig. 2, 85
 but a part of its action will be transmitted
 indirectly. The action of the pulse will store
 up some energy in those parts of the pilot
 wave conductor which are nearest to the
 antenna, and in these energized parts free
 90 oscillations will be started which are easily
 transmitted to the circuits containing local
 translating devices, because these oscillations
 are of low frequency. In the case described
 here the highest frequency of the free oscil- 95
 lations is about 18,000 p. p. s. and, as is
 shown in the curve A of Fig. 5, such a fre-
 quency is transmitted very efficiently over
 the pilot conductor just described. These
 free oscillations of low frequency should in
 100 the first place have a large decrement as is
 provided here by giving each section as
 large a resistance as is compatible with other
 considerations; in the second place they
 should be excluded from the local translat- 105
 ing devices by another pilot conductor which
 transmits the signalling frequency satisfac-
 torily but attenuates very rapidly lower fre-
 quencies. This second pilot conductor is an
 artificial cable which has at equal intervals 110
 in parallel arrangement suitable inductance
 coils and condensers connected in series.

Referring to Fig. 3, there is represented
 in this diagram, a sectional wave conductor
 consisting of, say, 14 pairs of approximately 115
 equal resistances 39, 40, . . . 52. Bridged
 across these are capacities 61, 62, 63, . . .
 74 in series with equal inductances 75, 76,
 . . . 88. The capacities are graded in value
 in accordance with a rule which will be ex- 120
 plained presently.

Let the inductance of each coil be
 $L = 2 \times 10^{-3}$ henrys, and let its effective re-
 sistance R be very small in comparison with
 the reactance, say

$$\frac{R}{pL} = .05,$$

where

$$p = 2\pi \times 25 \times 10^3.$$

125

130

Let the resistance R_1 of each resistance unit be $R_1=50$ ohms and the capacity C of each condenser be

$$C=4 \times 10^{-8} \text{ farads}$$

$$e^{2b} + e^{-2b} - 2 \cosh 2b = \frac{A^2 + B^2}{2} + \sqrt{\left(\frac{A^2 + B^2}{2}\right)^2 + 2(A^2 - B^2 - 2)}$$

where

$$A = 2 \left(1 + \frac{RR_1}{p^2 L_1^2 + R^2} \right)$$

$$B = 2 \frac{R_1 p L_1}{p^2 L_1^2 + R^2}$$

$$L_1 = L \left(1 - \frac{1}{p^2 LC} \right)$$

so that near the values of p which satisfy the resonance condition, namely $p^2 LC=1$, the attenuation constant would be enormous. For other values of p this constant would be small. That is to say, this pilot conductor would attenuate a very narrow interval of frequencies. This interval is widened very much by giving to the condensers 61, 62, 63, . . . 74, gradually increasing values as follows:

Capacity of condenser 61 is 4×10^{-8} farads

Capacity of condenser 62 is 4.28×10^{-8} farads

Capacity of condenser 63 is 4.58×10^{-8} farads etc., that is, each capacity is about 7 per cent higher than the preceding one, so that the last capacity is about 9.63×10^{-8} farads.

In this case the pilot conductor will attenuate very strongly a frequency interval of 40 per cent. below a given frequency. With the values given above for the constants L and C , this interval will be between about 12.5×10^3 p. p. s. and 18×10^3 p. p. s. and the attenuation power will be as indicated by the curve B of Fig. 5. But this is the interval of frequencies within which are located all the free periods of the first pilot conductor, and since these free oscillations of the first pilot conductor carry all the energy of the static it is clear that the second pilot conductor will dissipate it. This dissipation of the energy conveyed by the free oscillations of the first pilot conductor is carried out in practice by connecting the pilot conductor of Fig. 8 in series with the energizing circuit 16 of Fig. 2, giving a curve of attenuation power with respect to frequency as C in Fig. 5. Connected with the second pilot wave conductor is a system of conductors containing the translating devices. Thus in Fig. 3 is represented a resistance compensator connected to the second pilot wave conductor by the transformer 93, 94 leading to a resistance compensator of the vacuum tube type, described in application Serial No. 51,151 filed on

If the capacities were all equal and each equal to 4×10^{-8} farads, then the attenuation constant b of the sectional wave conductor would be given by the following formula:

165 dated March 16, 1920, by the applicant and E. H. Armstrong.

In place of the pilot wave conductor of the second type, just described, a third type of pilot wave conductor may be employed which also attenuates effectively frequencies below a given frequency. This third type of pilot wave conductor is represented diagrammatically in Fig. 4. This is the well known artificial cable consisting of a suitable number of equal resistances 101, 102, 103, . . . 108 and equal condensers 109, 110, 111, 112, 113, . . . paralleled by equal inductances 114, 115, 116, 117, . . . Let each resistance unit have a resistance equal to 200 ohms, each condenser have a capacity of 2×10^{-8} farads, and let each inductance be equal to 2×10^{-3} henrys, then the wave conductor will transmit well frequencies in the vicinity of 25×10^3 p. p. s. but will attenuate rapidly all low frequencies and particularly those below 15×10^3 p. p. s. The mathematical theory for all these and similar wave conductors can be obtained easily by following the mathematical method described by the author in the references cited above.

The broad invention consists in preventing all but a narrow range of frequencies from reaching the receiving circuits containing the translating devices by interposing suitable pilot wave conductors between these circuits and the conductors receiving the signalling wave energy, and I have described several of the best types of such pilot wave conductors, but I do not limit myself to these types.

In the practice of this invention it is not permissible to tune the antenna to the signalling frequency. If tuning is to be employed then the antenna should be tuned to a frequency different from the signalling frequency and preferably tuned to the highest natural frequency of the first pilot conductor so that the antenna and the first pilot conductor have one natural frequency in common which will be dissipated by the second pilot conductor.

I claim:

1. A wave receiving station having a receiving conductor and a local translating device, between which is interposed a two-part sectional wave conductor, one part of which has a large attenuation power for wave frequencies substantially higher than the frequency of the waves to be received, the sectional elements of that part of the

10

15

20

25

30

35

40

45

50

55

60

65

5

70

75

80

85

90

95

100

105

110

115

120

- sectional wave conductor having natural periods of oscillation of a frequency substantially less than the frequency of the waves to be received, the other part of the sectional wave conductor having a high attenuation power for low frequency waves including those resulting from the natural oscillations of the first part of the sectional wave conductor, the receiving conductor having a natural period of oscillation approximately corresponding to one natural period of oscillation of the first part of the sectional wave conductor.
2. A wave receiving station having a receiving conductor and a local translating device, between which is interposed a two-part sectional wave conductor, one part of which has a large attenuation power for wave frequencies substantially higher than the frequency of the waves to be received, the sectional elements of that part of the sectional wave conductor having natural periods of oscillation of a frequency substantially less than the frequency of the waves to be received, the other part of the sectional wave conductor having a high attenuation power for low frequency waves including those resulting from the natural oscillations of the first part of the sectional wave conductor, the receiving conductor having a natural period of oscillation corresponding to the highest natural period of oscillation of the first part of the sectional wave conductor.
3. A receiving station for radio frequency waves having a receiving conductor and a local translating device, between which is interposed a two-part sectional wave conductor, one part of which has a large attenuation power for wave frequencies substantially higher than the radio frequency of the waves to be received, the sectional elements of that part of the sectional wave conductor having natural periods of vibration of a frequency substantially less than the frequency of the waves to be received, the other part of the sectional wave conductor having a high attenuation power for low frequency waves including those resulting from the natural oscillations of the first part of the sectional wave conductor.
4. A wave receiving station having a receiving conductor and a local translating device, between which is interposed a two-part sectional wave conductor, one part of which has a large attenuation power for wave frequencies substantially higher than the frequency of the waves to be received, the sectional elements of that part of the sectional wave conductor having natural periods of vibration of a frequency substantially less than the frequency of the waves to be received, the other part of the sectional wave conductor having a large attenuation power for low frequency waves and being made up of sectional elements having natural periods of oscillation which differ from one another by small increments throughout a considerable range which includes the natural periods of oscillation of the first part of the sectional wave conductor.
5. A conductor of radio frequency waves selective with respect to a narrow range of frequencies comprising two series of sectional wave conductor elements, the number of elements of the first series being small per wave length of waves of substantially higher frequency than the waves of radio frequency to be conducted, whereby the attenuation power for waves of such frequency is high, and the individual elements of the series having natural periods of oscillation substantially less than the frequency of the waves to be conducted; the second series of wave conductor elements having a large attenuation power for low frequency waves including those resulting from the natural oscillations of the first series of wave conductor elements.
6. A wave conductor selective with respect to a narrow range of frequencies comprising two series of sectional wave conductor elements, the number of elements of the first series being small per wave length of waves of substantially higher frequency than the waves to be conducted, whereby the attenuation power for waves of such frequency is high, and the individual elements of the series having natural periods of oscillation substantially less than the frequency of the waves to be conducted; the second series of wave conductor elements having a large attenuation power for low frequency waves and having individually natural periods of oscillation which differ from one another by small increments throughout a considerable range, which includes the natural periods of oscillation of the first series of wave conductor elements.
7. A receiving system for discriminating between periodic sustained energy of a given frequency and disturbing energy, comprising a receiving conductor tuned to a frequency different from said given frequency, a translating device and a network connecting said conductor to said device, said network comprising a band filter for transmitting energy of a band of frequencies including said given frequency, and excluding the frequencies of all the natural oscillations of said network.
8. In a radio receiving system, an indicating instrument, a recurrent network of similar sections, said network containing damping resistance in each section, and means for transferring received energy to said indicating instrument through said network.
9. The combination at a signal station of

- a signal circuit and an electric wave filter connected thereto, said filter comprising a plurality of recurring sections, each of said sections comprising lumped resistance, lumped capacity and lumped inductance, said resistance, capacity and inductance having values depending upon the frequency of the impulses to be transmitted through said filter.
10. In a signaling system the combination of a detuned antenna, a frequency selective amplifying means associated therewith, and means including a band filter all the natural oscillation frequencies of which are outside the frequency transmission band of said filter associated with said amplifier for translating the signals.
11. A receiving system comprising a receiving conductor, a translating device and means including a wave filter connecting said receiving conductor to said device, said filter having a transmission range including a band of frequencies and excluding substantially all frequencies outside said band and having no natural oscillation frequency within said band.
12. The method of receiving signals free from static interference, which consists in selectively receiving signals in accordance with the frequency of forced oscillations and in damping free oscillations, for giving the frequency thereof a value different from that of the signal oscillations to be received.
13. The method of signal reception, which consists in damping the received oscillations for giving the frequency of free oscillations a value different from that of the signal oscillations to be received, amplifying the signal oscillations, and in selectively receiving the amplified signal oscillations to the exclusion of the different frequency free oscillations.
14. A receiving system comprising an energy receiving element, highly damped means selectively responsive to desired energy oscillations of a given signaling frequency which are to be received associated with said element, a receiving circuit and means for transferring energy from said highly damped means to said receiving circuit.
15. A signaling system comprising an energy receiving element and a highly damped circuit tuned to the frequency of desired signals directly associated with said element.
16. The method of receiving signals which comprises converting substantially all of the static energy received therewith into oscillations differing in frequency from that of said signals without changing the frequency of the received signal energy and selecting out the oscillations of the frequency of the received signal wave from said converted energy of different frequency.
17. A system for selectively transmitting periodic energy of a given frequency to the substantial exclusion of other energy, comprising a plurality of energy transfer devices arranged in tandem, each of said devices being highly damped and having its stiffness and inertia factors so related as to make said device most strongly responsive to periodic energy of the given frequency.
18. Means for eliminating the effect of disturbances upon transmission lines comprising means for imparting to substantially all of the disturbing energy a characteristic differing from that of the energy to be transmitted, and means for selectively transmitting to a translating device the energy to be transmitted, to the substantial exclusion of said disturbing energy of different characteristic.
19. A transmission system comprising a unidirectionally conducting element and a second unidirectionally conducting element and a band filter between said unidirectionally conducting elements, said band filter having a natural period of oscillation which is outside of the frequencies which it efficiently transmits.
- In testimony whereof I affix my signature.

MICHAEL I. PUPIN.